



Mick Leabeater retires as PIMA President

After three years as president of PIMA Mick Leabeater (ASP Plastics Pty Ltd) has retired from the position at the AGM held in November.

Mick thanked the committee for their support with a special thanks to Secretary/Treasurer Ralph Cable. He also thanked Keith Monaghan (RE Davison Pty Ltd) for the work he has done on the establishment of the new association (Plastics Manufacturers of Australia) and Mick hoped that all members will get behind this new organization as he felt that this was the way of the future for both the Plastics Injection Moulders Association and the Plastics Industry as a whole.

In closing, Mick wished the incoming president (Keith Monaghan) all the best for his term in office and offered his full support.

PIMA PRESS would also like to congratulate Mick on being re-elected (un-opposed) as the president of the Plastics Pioneers in NSW – this will be his 5th year as President (*who said he was going to ride off into the sunset*).



Important Diary Dates for 2006

Dinner Seminar	Tuesday	07/02/06
Plastics Pioneers Lunch	Thursday	24/02/06
Dinner Seminar	Tuesday	28/03/06
PIMA Charity Golf Day	Friday	12/05/06
Plastics Pioneers Lunch	Thursday	26/05/06
Dinner Seminar	Tuesday	11/07/06
Plastics Pioneers Lunch	Thursday	31/08/06
Dinner Seminar	Tuesday	05/09/06
Dinner Seminar & AGM	Tuesday	31/10/06
Plastics Pioneers Lunch	Thursday	30/11/06

2005/2006 PIMA Committee

The following committee positions were voted at the first committee meeting following the AGM. Congratulations to all those elected.

President:	Keith Monaghan (RE Davison)
Secretary:	Ralph Cable (Galvano Plastics)
Treasurer:	Ralph Cable (Galvano Plastics)
Membership:	Craig Cook (C&C Plastics)
Membership:	Peter Stewart (Marplex)
OH&S & Quality:	Peter Mandavy (ASP Plastics)
Past President:	Mick Leabeater (ASP Plastics)
General Committee:	Isaac Yeshouroun (Doric Products) Pat Primmer (Beba) Andrew Wiseman (W&S Plastics)

Merry Christmas to all

The PIMA Committee wishes all PIMA members and friends a Merry Christmas and a Happy & Prosperous New Year

Ausplas Roundup

The following report on AUSPLAS was printed in the Victorian Plastics Pioneers Newsletter. You may have a different view – we would love to hear it – Ed.

The following was kindly provided by Exhibition Management's Michelle Patterson, and it is literally "hot off the press". AUSPLAS 2005 (26-29 Sept.) NUMBERS DOWN. QUALITY UP!

Based on early statistical analysis of trade visitor data and interviews with exhibitors and visitors, Ausplas 2005 has reaffirmed its position as Australia's International-standard exhibition for the plastics industry. Held in Melbourne's Exhibition Centre, Ausplas 2005 occupied 15,000 square metres of exhibition space with an estimated 350 companies represented directly or via their agents.

Some 60% of visitors classified themselves as "Decision Makers" - CEO's 18%, GMs 13.2%, Purchasing Managers 7.7%, Technical Managers 19.4% and Production Managers 10.6%.

Executive Director of Exhibition Management, John Kelly advised: "I am really very confident in making the statement that possibly the 2005 event was the best in recent history if we are considering the amount of business seemingly generated".

"The official attendance was 5518, with 740 individuals re-visiting the event on a day other than their first visit. That is down by about 1800 visits from 2003 when Ausplas was held concurrently "with another trade show at this venue. Initially we were a little concerned with the drop on the first day, but the show picked up steam from Tuesday onward with many exhibitors very happy about the attendance on that late closing day in particular".

"27% of visitation was from interstate and internationals - a very high percentage as it is normally closer to 15%. 9% of visitors were from overseas with the largest contingent (280) from NZ. Others came from countries as far flung as Algeria and Vietnam. Major areas of activity for visitors were Packaging 22.7%, Auto 18.5%, Building 11.7% and Custom Moulding 10%".

The Best Stand Awards announced are:

- Best Custom Built Stand (Raw Materials) : BASF. Special mention went to Martogg.
- Best Custom Built Stand (Machinery): COMTEC IPE. Special mention to Cam-Plas Machinery. .
- Best Display System (Machinery): DKSH AUST.
- Best Display System (Other): ROCKWOOD PIGMENTS & TRADING.
- Best International Stand (Plastic News International): QATAR PETROCHEMICAL. Exhibition Management Pty Ltd will be conducting extensive post event research amongst exhibitors and visitors to assist with planning for Ausplas 2008. Exhibitors and visitors are welcome to provide their own comments on their Ausplas 2005 experiences by visiting www.ausplas.com

Dinner Seminars

PIMA dinner seminars are informative and a great chance to network with other members of the industry. We are currently putting together next years topics so if you wish to present something of interest or would like to suggest a topic that you feel would be of interest to others please contact Ralph Cable at pima@pima.asn.au . Providing the latest information to the industry is one of PIMA's major aims, so help us help you.



HEALTH & SAFETY Bulletin

Workplace stress doesn't go for a holiday

(The Australian Financial Review)

Stress leave may hinder not help workplace depression, according to depression initiative Beyond Blue. It is pushing the counter-intuitive message that allowing employees to take weeks off when it all becomes too much is not a good idea.

The organisation's Helen Rimington told this week's CPA Congress that "if someone says they are stressed, by sending them on stress leave you are not addressing the problem".

The underlying causes will remain on return to work and the time off can just exacerbate feelings of isolation, she says.

Her comments come at a time when depression counts for 6 million lost working days a year and psychological injury accounted for 7% of workers compensation claims in 2003-04.

WorkStation - October 21, 2005 edition*

This article was submitted by Peter Mandavy, ASP Plastics Pty Ltd

Policing mentality not the answer

Occupational health and safety based on a policing mentality is the antithesis of safety best practice, according to an executive with ANSTO, the Australian Nuclear Science and Technology Organisation.

Barrie Hill, ANSTO's general manager engineering services, says OHS based on such a mentality is a throw back to Australia's colonial past and its jailer/criminal syndrome. Mr Hill says it is characterised by many levels of supervision and management "abrogating responsibility for safety matters to other parties".

"Everything becomes the fault of the worker [crim] to be sorted out by profound documents [the law] and that can only happen on the basis of a carefully designed program with commitment from all levels. "Moving from complacency to commitment can, in itself, be a long process."

Mr Hill says he has seen remarkable turn around in safety cultures through long-term, consistent small changes driven by safety event reporting, investigation and implementation of subsequent improvement recommendations. The improvements have been driven solely by line management with occasional safety professional support.

Mr Hill will be a key speaker at The Safety Conference Sydney 2005, October 26-28. penalties defined by safety professionals [jailers]." He says the policing mentality is particularly evident in public service operations. Mr Hill says the ultimate success for safety professionals is to work themselves out of a job step-by-step. He says they should be able to quietly walk away from their operation knowing the safety culture they have developed and put in place is internalised, effective, self-sufficient and continuously improving. Mr Hill says good safety cultures can't be achieved overnight and evidence suggests about three years is required to turn around an operation to a proactive safety performance.

The plain-English guide to workplace health and safety. October 14 2005 edition.

This article was submitted by Peter Mandavy, ASP Plastics Pty Ltd



PIMA Charity Golf Day 2006

The PIMA Charity Golf Day will again be held at Carnarvon Golf Club on Friday 12th May 2006. More details will be mailed out and also will be in future editions of the PIMA PRESS. It is an Ambrose event so all levels of golfing ability are catered for. Keep the date available, start to organise your teams and put some funds aside in your budget for sponsorship. PIMA is proud that over the last two years we have raised \$60,000 for charity, so come along.



CONGRATULATIONS!!!

PIMA would like to congratulate our OH&S board member Peter Mandavy on being accepted for a Scholarship to attend the Safety in Design Conference, Nice, France in March 2006. The scholarship will be sponsored by the publisher's of OH&S Daily News ENEWS PUBLICATIONS PTY LTD and ASP Plastics Pty Ltd on a 50/50 basis. Peter would like to thank both organisations for their support.



ISSA

Peter will attend the International Social Security Association (ISSA) 9th International Symposium in Nice, France, with the participation of ISSA's Chemistry and Machine and System Safety Sections.

Objectives of the conference: Managing industrial efficiency mainly relies on an engineering-driven approach that focuses on the technical design and control of production systems, with little consideration given to what operatives actually do. Despite the wide range of design activities and approaches, very few have addressed occupational health and safety issues by considering human factors. It is, however, now crucial that an integrated approach be developed and implemented in order to achieve expected levels of performance.

The conference intends to examine the design process in order to identify:

- Ways of including the health and safety of operators as early as the design process (e.g. difficulties, methods, approaches, tools and examples of good practice);
- Needs of designers faced with the integration of human and safety factors in the design process (Why? When? How?);
- The role of standardisation and regulations in knowledge transfer;
- The ability of current design methods in integrating available operational data, such as ergonomic analyses, lessons learnt, etc.

Target audience: This multi-disciplinary symposium will interest all those concerned with occupational health and safety, and the competitiveness of companies (managers, designers, human-factor experts, occupational health and safety specialists, etc).

Advertising & Contributions

Advertising is now available in the PIMA PRESS. Advertisements should be submitted as a WORD file. Please contact Ralph Cable (Ph: 02 9387 6610 or pima@pima.asn.au) for more information.

Advertising rates are \$50 + GST for a quarter page.

We still need articles to be contributed. As PIMA PRESS is read by a large cross-section of the plastics industry articles do not need to be specific to Injection Moulding. Information on insurance, OH&S, raw materials, latest news on people and companies etc is welcome.

Trade Directory

Have you placed a FREE listing in the PIMA Trade Directory? You will find it attached to the PIMA website. Go to www.pima.asn.au and click on Trade Directory. If you have any problems contact Ralph Cable on (02) 9387 6610.

This directory has the potential to assist the industry with fast access to providers of goods and services to the industry but to improve this we need even more listings.

National Service Awards

Two Southern Highlands residents (*Plastics Pioneers*) were recently honoured for their contributions to Australia's military when they received National Service Medals.

Southern Highlands MP Peta Seaton presented the National Service medals to Cliff Francis and to Elaine Jenner, who accepted the medal on behalf of her husband, the late Alan Jenner.

National Service medals are presented to National Servicemen, also known as Nashos, who were conscripted into military service during the 1950s, 60s and 70s.

National Servicemen often completed their service in the Citizen Military Forces, and some served their country in India, Pakistan and Vietnam.

The commemorative medal is a physical reminder of their efforts and recognition of their service to the nation.

Both Mr. Francis and Mr. Jenner served in the Citizen Military Forces during the 1950s with both men completing their service at Holdsworthy.

Mr. Francis served with the Royal Australian Electrical and Mechanical Engineers in the wireless section of the Armoured Corps, while Mr. Jenner served in the Artillery.

Co-incidentally, Mr. Francis & Mr. Jenner met in the 1970s while both men were working in the plastics industry in Sydney.

As co-patron of the Southern Highlands branch of the Nashos, Ms. Seaton said she was proud to present Mr. Francis and Mrs. Jenner with the National Service Medal, saying their efforts were worthy of recognition.

This article was published in the Highlands Post words in (Italics added by PIMA Press)



Marion Francis, Cliff Francis, Peta Seaton MP, Elaine Jenner

Plastics Pioneers Christmas Lunch Meeting a Raging Success

The annual Christmas Lunch was held at the Rugby Club and once again a great time was had by all. Mick Leabeater was again elected President (unopposed) and it looks like next year will be another good year for the Pioneers.

If you feel you would like to join the Plastics Pioneers please contact Mick Leabeater of ASP Plastics Pty Ltd on (02) 9623 7677.

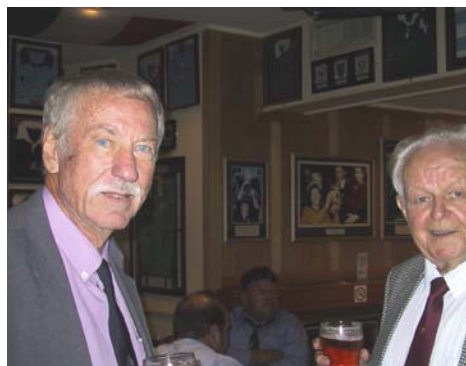

RIP John Stanborough - Plastics Industry loses another true Gentleman

At 2:30 am on Tuesday 6th December 2005 John Stanborough passed away and can now rest easy after fighting brain cancer since we all last saw him at the Plastics Pioneers Lunch back in February this year.

John was a hard worker and contributed much towards many different moulding companies.

These included Consolidated Plastics in Auckland, Cyclops Toys, Felt & Textiles Moulding, and Vinyl-Clad in Sydney before joining Johns Hydraulics in 1976.

John continued with Johns until their ultimate demise in 1988 and then finished his plastics career with Roberts Manufacturing at Brookvale.

John continued working part time for a friend's cleaning business until his illness stopped him.

Fellow Plastics Pioneers, PIMA members, friends and family alike will sorely miss John.

Thanks to Jim Patterson for submitting this obituary

ARRK Australia & New Zealand Pty Ltd
ABN 32 060 673 396
Hawthorn Office
5 Lynch Street Hawthorn VIC 3122 Australia
Tel: +61 (0)3 9819 4422 Fax: +61 (0)3 9819 4408
Email: info@arrk.com.au



FREE ARRKQUOTE ON-LINE CALCULATOR

Arrk is pleased to announce the release of its free on-line Rapid Prototyping calculator called ArrkQuote.

ArrkQuote is a free windows based software application that has been specifically developed by Arrk to allow customers to instantly calculate quotations for prototyping on their PC and place orders online 24 hours a day, 7 days a week.

There are many benefits customers gain through using ArrkQuote:

- **Reduce quote time:**

The automatic quotation you receive is an instant response to your specific prototyping requests.

- **Access to quoting 24 hours a day, 7 days a week:**

It is not unusual to be working over-time on an urgent project, and the ability to receive quotes and place orders at any time of any day prevents delays.

- **Setting budgets:**

ArrkQuote is capable of providing customers with accurate costing based on expected length, width, height and volume of a part design. Enabling customers to set appropriate budgets before commencing design projects.

- **Improved confidentiality and data security:**

When calculating a quotation, your data never leaves your computer. The software only extracts certain parameters from the file, which is transferred over a secure internet connection to Arrk's server. This method ensures full confidentiality of your project. It is only at the stage when you decide to proceed to order, that the CAD data is encrypted, compressed and transferred to Arrk via a secure connection.

Computer requirements needed to run the program:

- ArrkQuote is a Windows desktop software – Windows 98/ME, NT4.0/2000/XP
- Computer must be connected to the Internet to perform calculations and orders
- Microsoft based products (Microsoft Internet Explorer 5.5 or higher)
- Minimum compute requirements P11 with 128MB RAM
- Will only calculate STL files
- Proxy server and firewall configurations may prevent the use of ArrkQuote in certain organisations.

To receive your free copy of ArrkQuote, please email Kathryn Hay at Arrk kathryn@arrk.com.au and a CD will be sent to you to install.

22nd November 2005

ROTEQ Australia introduces Rydlyme, a non-toxic, non-corrosive, non-flammable and non-dangerous biodegradable de-scaler that cleans water systems without the need for disassembly of heat exchangers and other related equipment. Rydlyme is an easy to use, quick and safe way to keep the hidden costs of water scale under control.

It is a well known fact that despite the best efforts in water management, all cooling water systems generate a degree of scale and rust over time. In dollar terms the cost of this scale is difficult to calculate but it can be significant in an industry dependant on efficient cycle times. Regular cleaning with Rydlyme can help keep these hidden costs under control.

Closed Circuit Cooling System

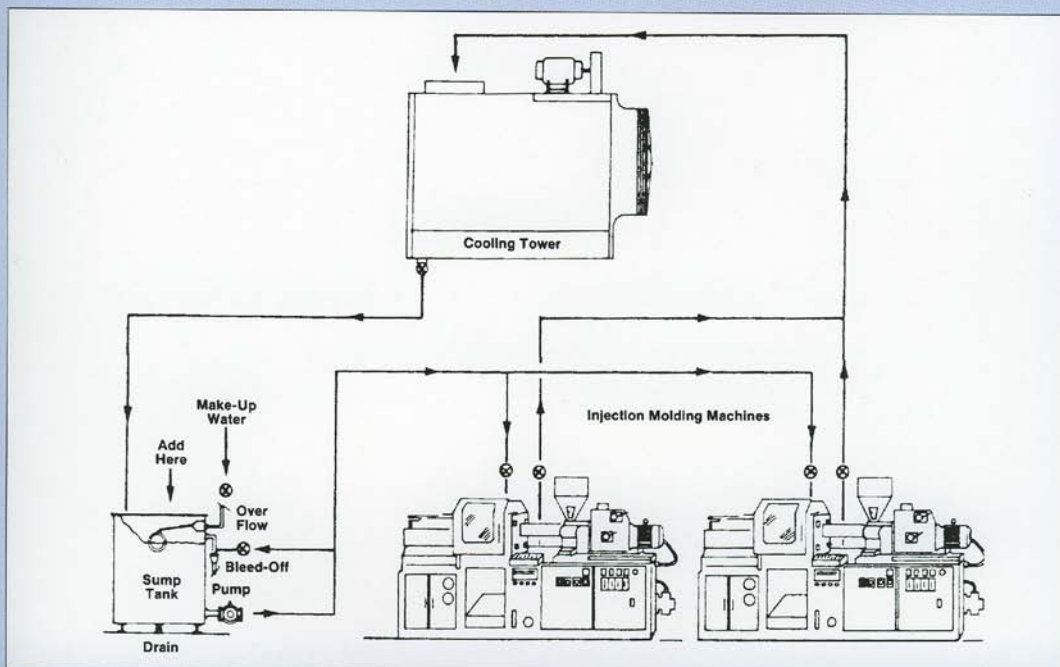

Cleaning of closed circuit water cooling systems is most usually accomplished while the water cooled equipment is on line and without the necessity of a shutdown.

Temperature Control Unit

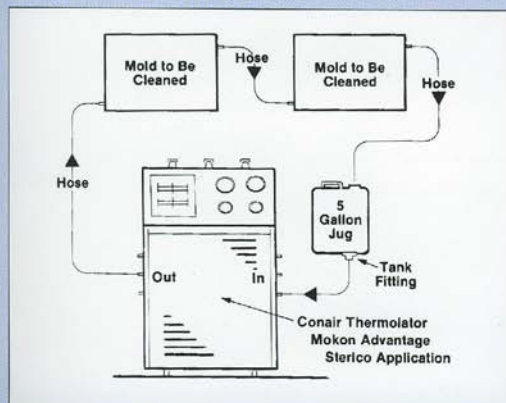

Support equipment, such as chillers, exchangers, temperature controllers and cooling towers are a vital part of your operation and can only afford you efficient operation when kept clean of water scale, lime and rust deposits.

Call or write for detailed instructions on any piece of your water cooled equipment that requires cleaning.

Heat Exchangers

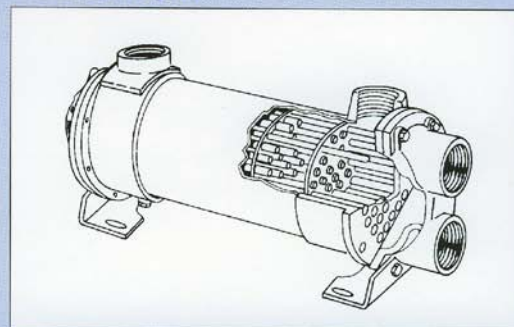

Any type of water cooled heat exchanger can usually be cleaned with **RYDLYME**. Hydraulic oil coolers that become fouled with water scale, lime and rust deposits will eventually cause a shutdown of expensive production equipment.

Periodic **RYDLYME** cleaning of your hydraulic oil coolers will keep this and other equipment operating efficiently.

RYDLYME is our solution to your problems.

For further details please call Richard Dixon on 0424 468 855 or visit www.rydlyme.com.au.

2005 CAD Inducted

Geoffrey Cook was last week named “CAD 2005” at the Annual CAD’s Cup luncheon held this year at City Tattersalls Club, thus carrying on a tradition commenced back in 1950 based on an incident at the old PIA (Plastics Institute of Australia) Golf day.

In those times the golf day was actually a weekend, held in the Blue Mountains. In 1950, inclement weather forced the golfers off the links to pursue entertainment other than golf. Back at their hotel - The Ritz at Leura, cards and snooker were popular, but some of the lads were a little more adventurous. One of them, Eddie Clouston was observed in alleged amorous pursuit (either real or imagined – the fog of history shrouds that in mystery, the passage of time leaving no witness). At a subsequent PIA meeting, Laurie Farrer of the since defunct Australian Plastics Journal presented the original CAD’s Cup to Eddie Clouston. The following year Clouston returned the favour, re-presenting the Cup to Farrer with the added motto “Honi soit qui mal y pense”. This is old French for “Shame be to him who thinks evil”. Each year following, the CAD’s Cup passed to a plastics industry personality adjudged by the incumbent CAD to be a suitable recipient.

Becoming the 56th CAD in an unbroken line of succession traceable back to that time, Geoff will be expected to uphold the infamous custom of bearing the “Cup” whenever present at a Plastics Industry gathering. Failure to maintain the presence of the “Cup” at any of these events can be expensive, incurring Geoff’s liability to shout drinks for any CAD who may be present. Conversely in possession of the Cup, Geoff can demand a drink from any CAD. Possession of the Cup is thus of high priority to the incumbent CAD and over the years various odd strategies have been developed by individual CADs to ensure retention.

The list of prior recipients of CADs Cup reads like a who’s who of the NSW Plastics Industry. Sadly, of the 56 CADs awarded the honour, only 33 remain with us.

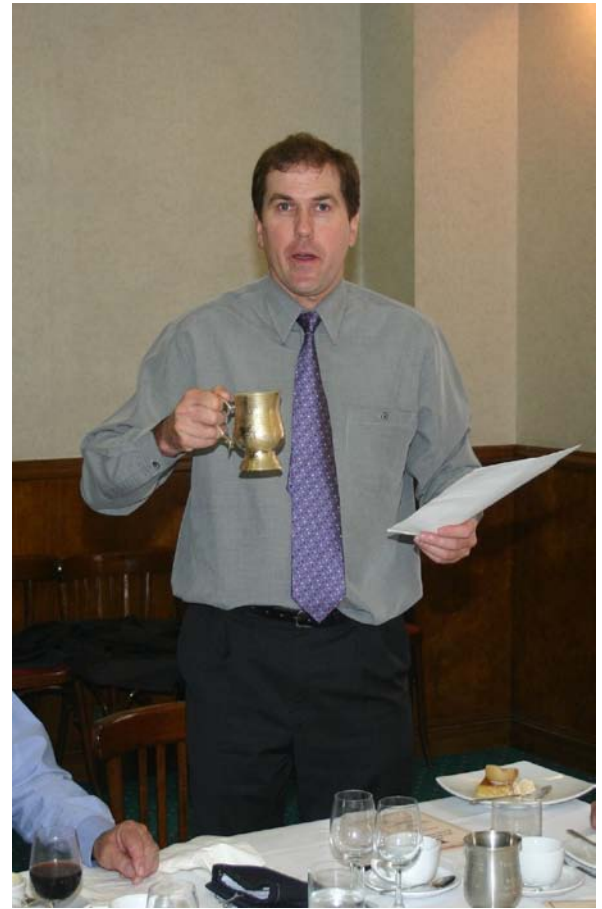

It has been common practice for infamous misdeeds of the incoming CAD to be enumerated by the incumbent CAD prior to the award being made. It was with great interest therefore that the fellowship of CADs awaited the description of Geoff Cook’s nefarious activities. Alas! Presenting CAD John Wellman proved to be too much of a gentleman (for a CAD!!) to indignify the gathering with this information. However observation of Geoff’s behaviour as the long luncheon progressed provided ample proof of his suitability for the dishonour.

How does one get to become a CAD?? Simply behave like a CAD!! But remember: “Honi soit qui mal y pense”.

The Editor wishes to thank Ern Molloy (1985 CAD) for submitting this article.

PIMA

PO BOX 324, Lidcombe. NSW.
2141

Ph: (02) 9387 6610 Fax: (02) 9387 6924

Email: pima@pima.asn.au